

3/4" Metallic Models

COMPACT SERIES PUMPS

Part of our Compact Series of pumps our 3/4" metallic pumps feature big performance in a small package. They achieve flow rates up to 14.8 GPM (56 LPM) and offer a wide range of material and porting configurations.

UPGRADE
PUMP FOR REMOTE
ACTUATION CAPABILITY

| | |
|----------------------------------|---|
| Ratio: | 1:1 |
| Maximum Flow: | 13.6-g.p.m. (51.5-l.p.m.) |
| Displacement per cycle: | 0.030-Gallons (0.11-Liters) |
| Air Inlet: (Female) | 1/4 - 18 P.T.F. SAE Short |
| Fluid Inlet/Outlet: | 3/4 - 14 N.P.T.F.-2 Rp 3/4 (3/4 -14 BSP, parallel) |
| Max. operating pressure: | 100-psi (6.9-bar) |
| Suspended solids max. dia.: | 3/32" (2.4-mm) |
| Weight: lbs (kg) | PX07R 8.74 (3.96) PX07A 11.0 (4.99) |
| Maximum dry suction lift: ft (m) | 15 (4.5) |
| Sound Level: | 70 PSI 60 Cycles/Min 75 db(A) |



PD07R-AAS-FAA

Ordering

| Position | 1 | 2 | | 3 | 4 | 5 | | 6 | 7 | 8 | | 9 | 10 | 11 |
|----------|------|---|---|---|---|---|---|---|---|---|---|---|----|----|
| Example: | PX07 | X | - | X | X | S | - | X | X | X | - | A | X | X |

| Position 1 Model Series | Position 2 Center Section | Position 3 Connections | Position 4 Wetted Parts | Position 5 Hardware | Position 6 Seat Material | Position 7 Ball Material | Position 8 Diaphragm Material | Position 9 |
|---|------------------------------------|---|----------------------------|------------------------|-----------------------------------|--|--|--|
| D - Standard Pump E - Remote Actuation Capable | A - Aluminum* R - Polypropylene | A - 3/4 - 14 N.P.T.F.-2 B - Rp 3/4 (3/4 -14 BSP, parallel) | A - Aluminum* | S - SS | F - Aluminum P - Polypropylene | A - Santoprene® C - Hytrel® T - PTFE | A - Santoprene® C - Hytrel® L - Long-Life PTFE T - PTFE | Revision Level Position 10 & 11 Specialty Code Fluid control options for pump with electronic interface (PE07 model). See complete description on page 33 |

* Acceptable for use in hazardous locations. - NEC / CEC: Class I&II, Div 1&2, Group A-D
- ATEX: Zone 1&2, 21&22

Hytrel® is a registered trademark of DuPont company, Santoprene® is registered trademark of Monsanto and Viton® is a registered trademark of ExxonMobil

Accessories

- Air Line Connection Kit** | 66073-1
(Piggyback Filter/Regulator with gauge, pipe nipple and 5-foot air hose)
- Wall Mount Bracket Kit** | 76763
- Optional Muffler** | 93110 used with 637438 kit
- Service Repair Kits** | 637428 (air section)
637427-XX (fluid section)



3/4" Metallic Dimensions and Flow Charts

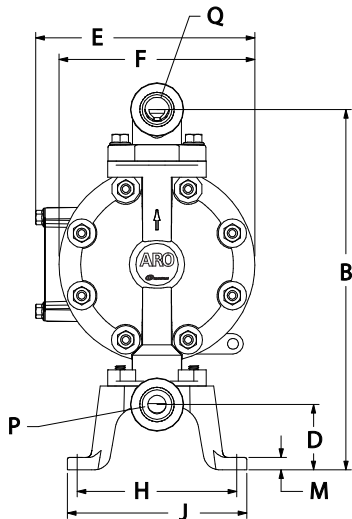
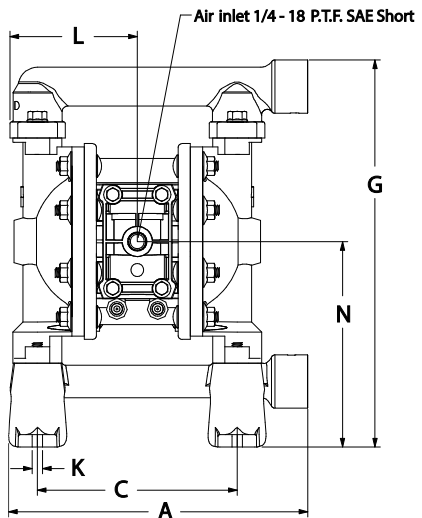

DIMENSIONS

| | | |
|-----------------------|------------------------|----------------------|
| A - 9-9/32"(235.3mm) | F - 6" (152.4 mm) | L - 3-29/32"(99.2mm) |
| B - 11-1/16"(280.4mm) | G - 11-7/8" (301.2 mm) | M - 3/8" (9.5mm) |
| C - 6-1/8"(155.6mm) | H - 4-29/32"(124.2 mm) | N - 6-5/16"(159.8mm) |
| D - 2" (50.8mm) | J - 5-1/2"(139.7mm) | |
| E - 6-23/32"(170.6mm) | K - 5/16"(8.0 mm) | |

| | | |
|---------------|---------------------|---------------------|
| Model | "P" Material Inlet | "Q" Material Outlet |
| PD07R-AAS-PXX | 3/4- 14N.P.T.F. - 2 | 3/4- 14N.P.T.F. - 2 |
| PD07R-BAS-PXX | Rp 3/4(3/4- 14BSP) | Rp 3/4(3/4- 14BSP) |

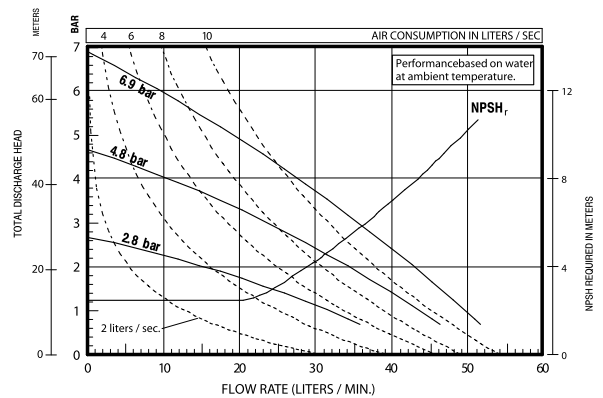
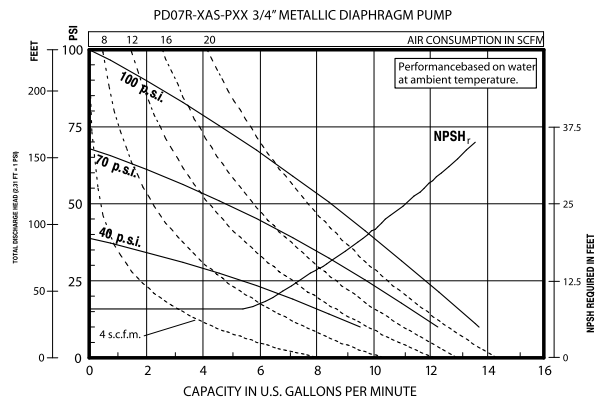

Performance based on an elastomeric fitted pump, flooded suction with water at ambient conditions. Due to varying materials of construction, assembly configurations and operating conditions, published data is for reference only

Ordering Position 10

Specialty Code 1 (Blank if no Specialty Code)

| | |
|---------------------|--|
| A - Solenoid 120VAC | G - Solenoid 12VDC ATEX/IECex* |
| B - Solenoid 12VDC | H - Solenoid 24VDC ATEX/IECex* |
| C - Solenoid 240VAC | J - 120VAC NEC/CEC* |
| D - Solenoid 24VDC | K - Solenoid 220VAC ATEX/IECex* |
| E - 12vDC NEC/CEC* | N - Solenoid with no coil |
| F - 24vDC NEC/CEC* | O - Standard Valve Block (No Solenoid) |
| | P - Ported Motor (No major valve provided) |

Ordering Position 11

Specialty Code 2 (Blank if no Specialty Code)

| | |
|--|--|
| E - End of stroke feedback + Leak Detection | L - Leak Detection |
| F - End of stroke feedback | M - Leak Detection ATEX/IECex/NEC/CEC* |
| G - End of Stroke ATEX/IECex* | O - No Option |
| H - End of Stroke/Leak Detection ATEX/IECex* | R - End of Stroke Feedback NEC / CEC* |
| | T - End of Stroke Feedback + Leak Detection NEC / CEC* |

* Acceptable for use in hazardous locations. - NEC / CEC: Class I&II, Div 1&2, Group A-D
- ATEX: Zone 1&2, 21&22